

Copyright (c) 2006

J D SQUARED INC.

www.jd2.com

NOTCH MASTER

Tube and Pipe Notcher Operating Instructions

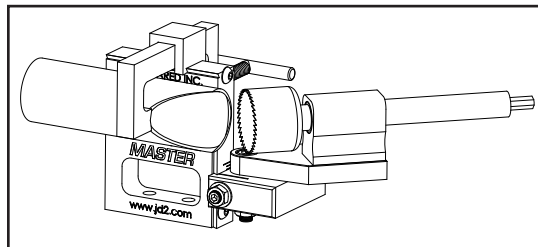
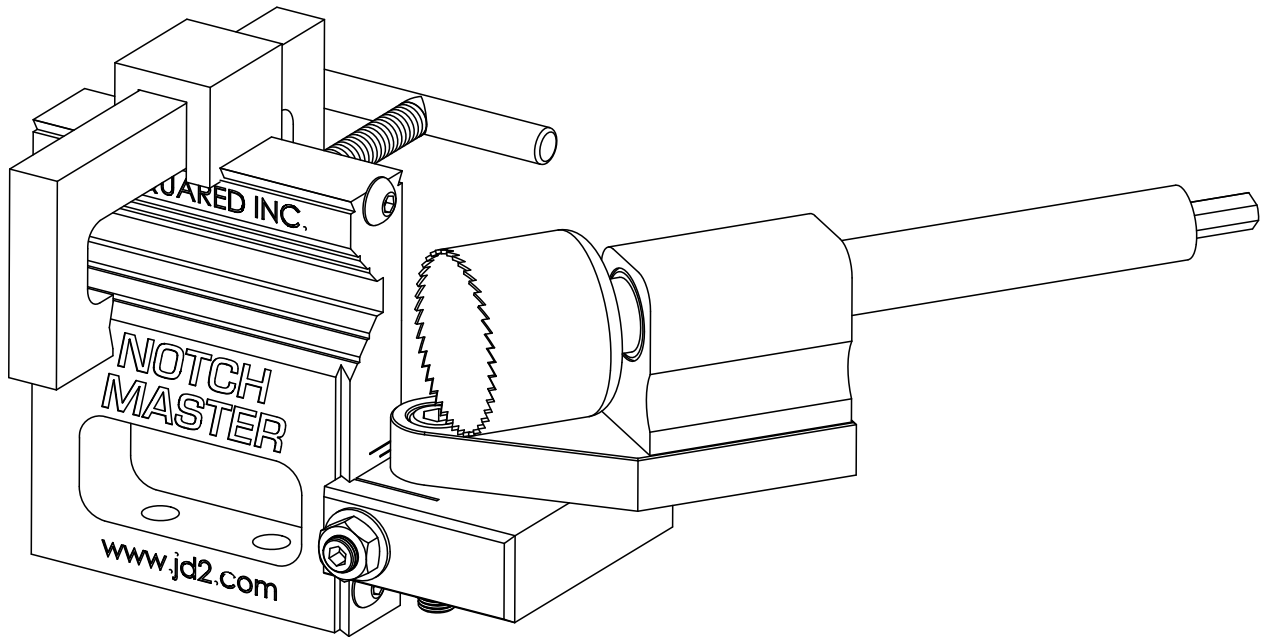

Angled Notches

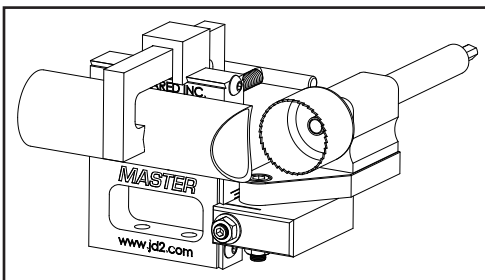

Straight Notches

PATENT PENDING

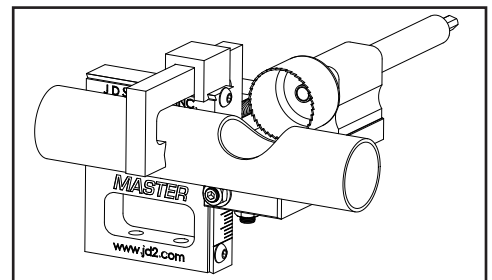

Offset Notches

Exploded View

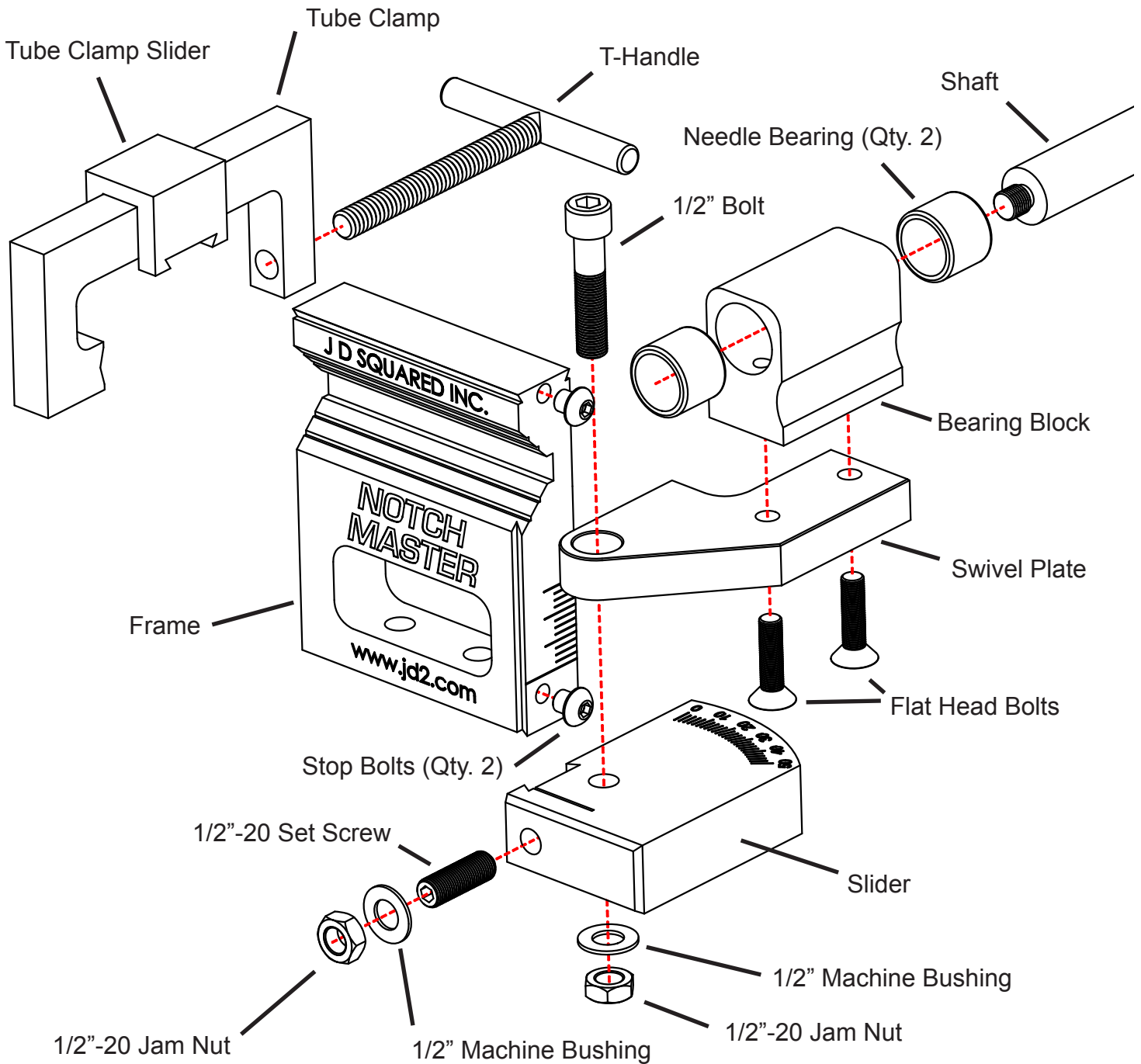

PARTS LIST:

- | | | | |
|---|--|---|-----------------------------------|
| 1 | Frame | 1 | 1/2"-20 Socket Head Cap Screw |
| 1 | Slider | 2 | 1/2" Machine Bushings (.875" OD) |
| 1 | Swivel Plate | 2 | 1/2"-20 Jam Nuts |
| 1 | Tube Clamp | 2 | 3/8" Button Head Socket Screws |
| 1 | Tube Clamp Slider | 2 | 3/8" Flat Head Socket Screws |
| 1 | T-Handle | 1 | Holesaw Adapter |
| 1 | Bearing Block | 1 | Holesaw Adapter Washer (.650" ID) |
| 1 | Shaft (1" Ground and Polished Stainless Steel) | 1 | 1/2" SAE Washer (1.065" OD) |
| 2 | Double Sealed Needle Bearings (1" ID) | | |

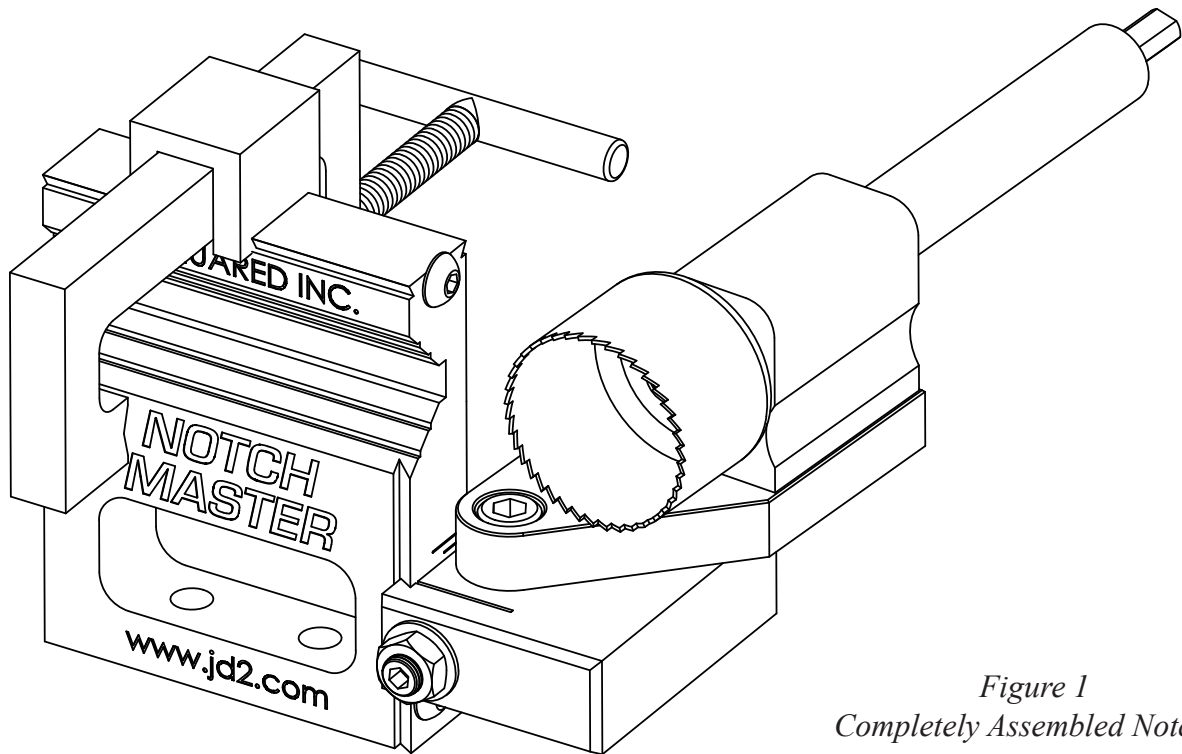

*Figure 1
Completely Assembled Notcher*

Assembly

After unpacking the notcher it will need final assembly. The completely assembled notcher is shown above. Refer to the Exploded View drawing on page 1 to help identify the parts and their orientation.

- 1) Starting with the bare frame, install the Slider onto the frame's side dovetail with the degree scale facing up. Install the Stop Bolt into the side of the Frame. The Stop Bolt's function is to allow the notcher to be quickly and easily returned to the zero position after an offset notching operation. If the Stop Bolt's head is too large to allow the Slider to return to zero you may need to slightly sand its o.d. to size. Install the 1/2"-20 Set Screw into the Slider and tighten. Place a 1/2" Machine Bushing and Jam Nut onto the Set Screw and tighten until the Slider is secured. Be careful not to over tighten.
- 2) The Bearing Blocks are shipped with the Bearings and Shaft pre-assembled. Using two 3/8" Flat Head Bolts, attach the Bearing Block to the Swivel Plate. Verify the bolt heads are below the surface of the Swivel Plate.
- 3) Install the Swivel Plate onto the Slider using the 1/2" socket head cap screw, a 1/2" machine bushing and a 1/2" jam nut. Adjust to zero degrees and tighten.
- 4) Using page 1 as a guide for part orientation, slide the Tube Clamp into the Tube Clamp Slider. Install the Tube Clamp Slider onto the notcher from the Bearing Block side. Install the last Stop Bolt into the side of the Frame. Install the T-Handle into the rear of the Tube Clamp. YOU'RE DONE!

Mounting

The notcher may be mounted in one of four ways.

- 1) Simply c-clamp it to your work table.
- 2) Using the frame's bottom two 1/2" holes, it may be bolted to your work table. The bolts will need to be installed head down so that the nuts will be visible in the Frame's rectangular opening.
- 3) Clamp it into a vise.
- 4) Using the Tube Clamp and V-Groove, clamp it directly to the tubing or pipe. This last method may be used to perform a notch in an existing structure.

Always place the 1/2" SAE Washer onto the shaft before either the Adapter or Holesaw. It prevents the shaft from entering the Bearing Block too far and allowing dirt and debris to enter the bearings.

Hole saws come in two sizes of mounting threads. Most hole saws require the use of the adapter and adapter washer. Install the hole saw onto the shaft as shown in figure 2. The washer is very important as it prevents the hole saw's threads from stripping during operation.

NOTE: Use only Bi-Metal hole saws. They can be purchased at most hardware and home improvement stores.

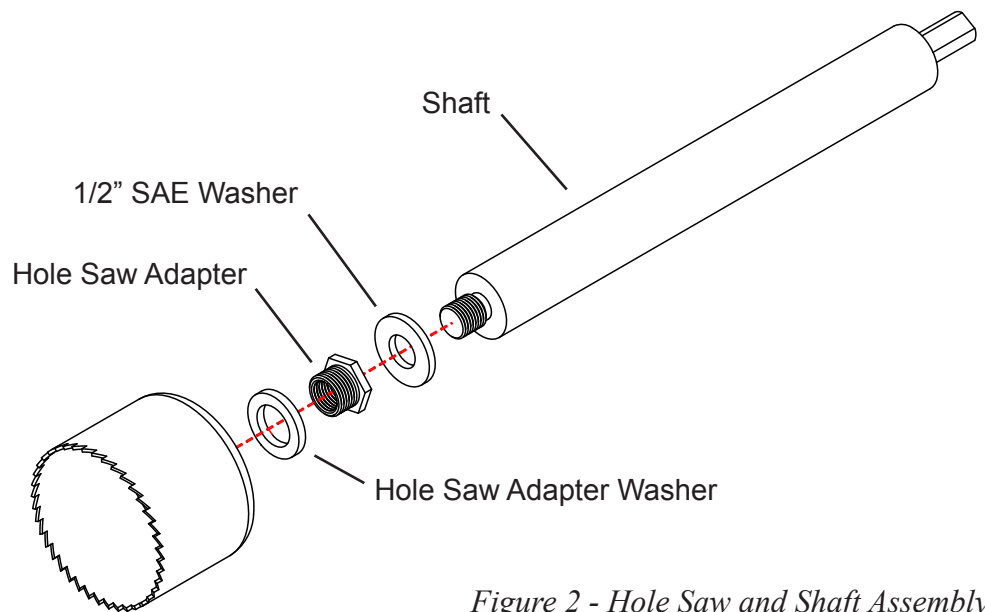

Figure 2 - Hole Saw and Shaft Assembly

Operation

The notcher requires a 1/2" hand drill for operation. The shaft has been milled on 3 sides to prevent the chuck from slipping and therefore works great with a keyless chuck.

STRAIGHT AND ANGLE NOTCHING

Adjust the notcher to the angle desired. Place the tube into the V-Groove and slide the Tube Clamp as close as possible to the hole saw without cutting into the Tube Clamp itself. Tighten the Tube Clamp securely. As a general rule, try not to notch through the whole tube at one time. Place the tube into the notcher so that as the hole saw cuts through the tubing it barely misses the middle of the tube's end when cutting. This can easily be seen in figure 5. This allows the first half to break off before the hole saw cuts the second half. If you must cut through the entire tube you will probably bottom out the hole saw. This occurs when you notch angles. Simply retract the hole saw and using a pair of pliers bend back the cut piece so the saw may continue cutting. Don't worry, it's easier than it sounds. If the notcher is cutting slightly off center you can adjust the Slider vertically to correct the problem. Keep in mind that as you change blade sizes, the cutting forces also

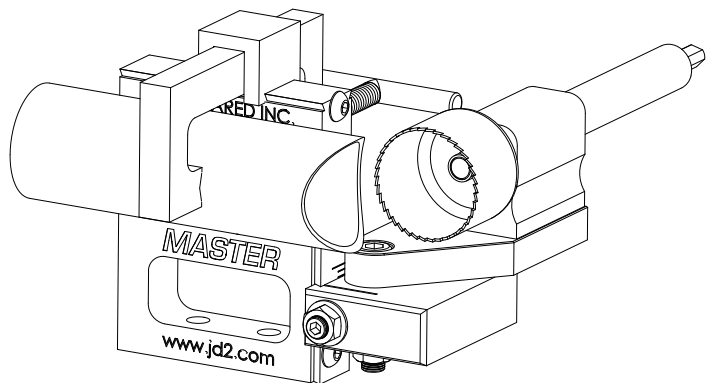

Figure 3 - Making a Straight Notch

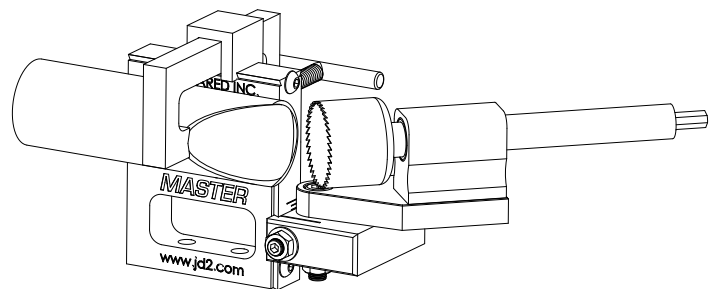

Figure 4 - Making an Angle Notch

change usually resulting in a very slight alignment error. However, once the tube is welded in place you will never notice it. Use a spray lubricant while cutting and feed the hand drill with a steady but unforced feed. Usually a notch can be made in 7-11 seconds.

ALWAYS HOLD THE DRILL FIRMLY AND NEVER USE EXCESSIVE FORCE WHEN PUSHING. Do not forget that the hole saw could hang up in the tube if forced too hard and kick back the drill in the opposite direction. This can sprain your wrist or worse. This is a trait of all hole saws even when not used in a notcher. Also, needless to say the hole saw is exposed, so keep your clothing and ALL body parts clear of it when cutting and wear eye protection. Jewellery, especially neck wear is also a potential danger around rotating machinery. PLEASE BE CAREFUL.

A major feature of the NOTCH MASTER is that the Swivel Mount adjust for the angle of cut. This is a huge advantage over other notchers including our own TN-100. Why? Because no matter what the angle of cut the tubing is always in the same position. This allows simple fixtures to be made to hold the tube horizontal if it's a long piece and also to precisely locate the tube for multiple pieces. It also allows the notcher to be mounted closer to walls. Because the long lengths of tube never rotate it saves shop space.

OFFSET NOTCHING

Offset notching is shown in figure 6. Essentially, you use the same procedure as in straight or angle notching. First, loosen the clamp nut on the Slider and observing the scale on its side adjust it to the desired offset. Locate the tube in the notcher and tighten the Tube Clamp. While cutting, the hole saw will almost certainly bottom out before it's through the tube. If it does, retract the saw and using a flat screw driver pry the cut piece up and away from the blade. Needle nose pliers may be needed here. Now just continue cutting.

One last tip, many users purchase multiple shafts for their notcher. Why? They mount their most popular hole saw sizes in different shafts and when they need to change sizes they simply slide the existing shaft out and slide the new one in. Saves considerable time and effort. Cool huh?

If you have any questions please call or visit our web site at www.jd2.com and navigate to the NOTCH MASTER page. There you can find further help in the way of photos and videos. We at J D Squared sincerely thank you for your business and hope your projects all go well.

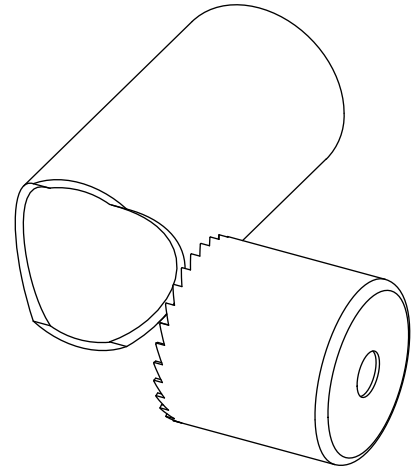

Figure 5 - Proper amount of tubing to remove. Notice that the middle of the tube is not cut.

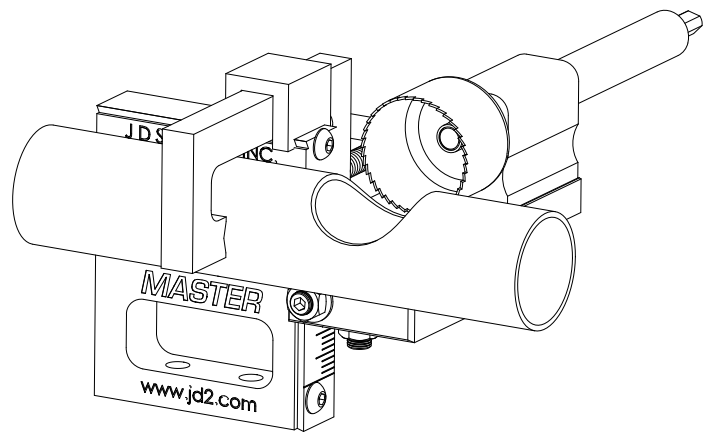

Figure 6 - Making an Offset Notch

J D Squared Inc.

2244 Eddie Williams Rd., Johnson City, TN 37601 USA

(423) 979-0309 FAX (423) 979-2426

www.jd2.com